

The requirements for stands in the industrial metrology are varied. As a specialist in stand construction, FOBA also offers special stands that are precisely adapted to the needs of customers. Because the product portfolio of FOBA is very broad, the most diverse standard components can often be combined to address customer needs. If that isn't enough, the appropriate stand can be developed together with the customer.

Examples of special stands



Example 1 (left picture)

Requirement:

- It should be possible to move the stand precisely.
- Several cameras should be able to photograph simultaneously with a similar position
- It should be possible to finely adjust the position of the cameras in relation to one another

Solution:

- AROBI column stand on a MUFUS with MURAI rail
- Longer horizontal beam
- 2 special holders on the horizontal beam hold 2 ASNEU tubes, on which 3 ASNAO camera brackets are mounted so that they can be swivelled and moved horizontally.

Example 2 (right picture)

Requirement:

- The stand should be able to hold a heavy sensor
- It should be possible - with fine movements - to precisely position the sensor on top of the object to be measured
- In order to save space, the shaft should be mounted on a workbench (not a cast base)

Solution:

- AROBI studio stand mounted on a table with 2 special MUWANS
- Swivelling fork at the end of the horizontal beam to hold the sensor
- A modified ALFEA crank guarantees fine vertical movements with or without the sensor



STURDY STAND FOR MEASURING ARMS

Measuring arms in labs and measuring rooms need a firm foothold, but must also be mobile. FOBA offers a stand for portable measuring arms that fulfils both prerequisites, and this in the traditional modular FOBA manner.

The stand for measuring arms is composed of the following elements:

- **ASLEO**, flange with 3.5" thread
- **ASABE**, shaft extension
- Stable **cast base**

ASLEO

Shaft flange with 3.5" thread for measuring arm



ASABE

Shaft extension, is screwed onto the cast base below; the ASLEO flange is fixed at the top.

ASABE is available in 3 standard lengths:

25 cm, 50 cm (both in the picture) and 100 cm. Several ASABEs can also be screwed together. Special lengths are also available upon request.



Cast base

Two different cast bases are available:

- Base from the ASABA studio stand: for high stability
- Base from the AROBI studio stand (in the picture): for gentle lowering of the measuring arm to the ground (installed shock absorber)

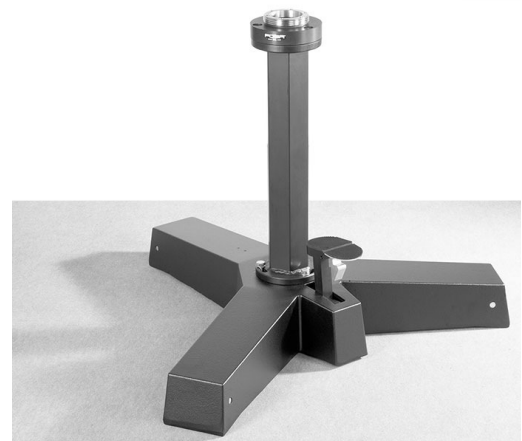

Subject to technical modifications 04/2014

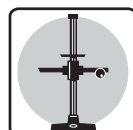

Made in Switzerland
Made by **FOBA**[®]